



Model: 116765-00 - 7610094
116765-13*

DESCRIPTION

- Three stage
- 120 volts
- 5.7"/145 mm diameter
- Double ball bearings
- Single speed
- Tangential bypass discharge
- Aluminum fan end bracket
- Aluminum commutator bracket

DESIGN APPLICATION

- Equipment operating in environments requiring separation of working air from motor ventilating air
- Designed to handle clean, dry, filtered air only

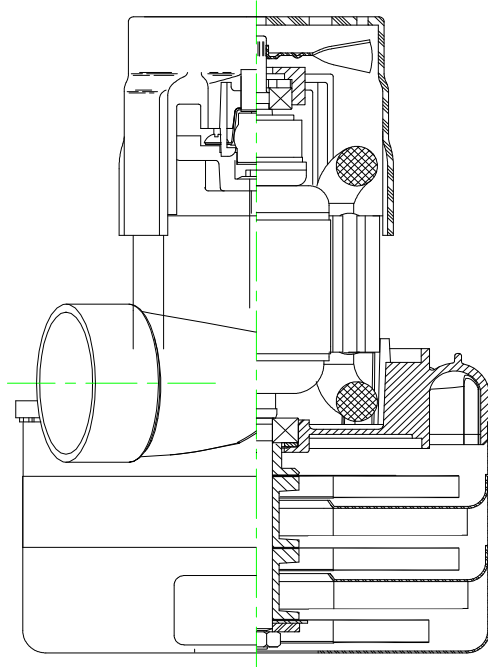

SPECIAL FEATURES

- Suitable for 120 volt AC operation, 50/ 60 Hz
- UL recognized, category PRGY2 (E47185)
- CSA Certified, class 1611 01 (LR31393)
- Provision for grounding
- Open frame design
- 10mm shaft and bearing system
- Aluminum fan end bracket designed to dampen vibration and improve durability
- The Lamb Electric vacuum motor line offers a wide range of performance levels to meet design needs
- *Model 116765-13 features patented air seal protection, U.S. Patent #4,088,424 and epoxy painted fan case**

TYPICAL MOTOR PERFORMANCE.*

(At 120 volts, 60Hz, test data is corrected to standard conditions of 29.92 Hg, 68° F.)

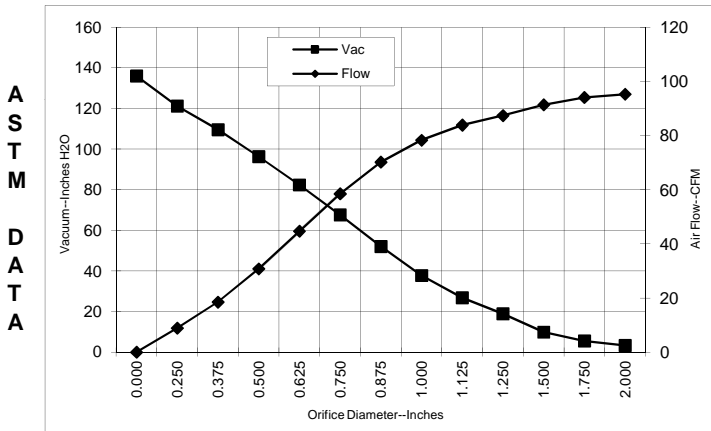

Orifice (Inches)	Amps	Watts (In)	RPM	Vac (In.H2O)	Flow (CFM)	Air Watts
2.000	12.6	1447	20822	3.3	95.3	37
1.750	12.7	1450	20797	5.6	94.1	61
1.500	12.8	1458	20762	9.9	91.4	107
1.250	12.8	1467	20675	18.9	87.4	195
1.125	12.9	1475	20592	26.8	83.9	264
1.000	13.1	1495	20502	37.8	78.3	348
0.875	13.1	1502	20440	52.1	70.2	430
0.750	12.9	1479	20587	67.6	58.5	465
0.625	12.4	1413	21112	82.4	44.7	432
0.500	11.4	1303	21990	96.3	30.8	348
0.375	10.3	1176	23082	109.6	18.5	238
0.250	9.4	1086	24247	121.2	8.9	127
0.000	8.6	1005	25312	136.0	0.0	0

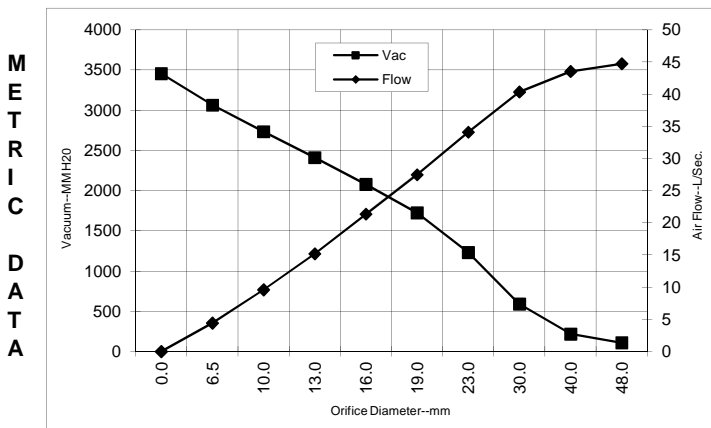

Orifice (mm)	Amps	Watts (In)	RPM	Vac (mm H2O)	Flow (L/Sec)	Air Watts
48.0	12.7	1448	20811	109	44.7	48
40.0	12.7	1456	20773	218	43.5	93
30.0	12.9	1471	20629	590	40.3	233
23.0	13.1	1500	20456	1233	34.1	410
19.0	12.9	1478	20598	1725	27.5	464
16.0	12.4	1416	21091	2078	21.4	433
13.0	11.5	1314	21902	2411	15.2	356
10.0	10.4	1195	22918	2733	9.6	255
6.5	9.4	1091	24189	3064	4.4	133
0.0	8.6	1005	25312	3454	0.0	0

Note: Metric performance data is calculated from the ASTM data above.

* Data represents performance of a typical motor sampled from a large production quantity. Individual motor data may vary due to normal manufacturing variations.

Test Specs:	120 volts	Minimum Sealed Vacuum:	130.0"	ORIFICE:	7/8 "	Minimum Vacuum:	48.0"	Maximum Watts:	1700
-------------	-----------	------------------------	--------	----------	-------	-----------------	-------	----------------	------

DIMENSIONS

NOTES:

1. LEADS: 18GA STRANDED, LEADS CAN BE ANY COLOR EXCEPT GREEN OR GREEN WITH YELLOW STRIPE.
2. GROUNDING OR EARTHING PROVISIONS: USE HOLES AS INDICATED FOR GROUNDING OR EARTHING. REFER TO APPROPRIATE LISTING OR REGULATORY AGENCY FOR PROPER METHOD OF GROUNDING OR EARTHING.
3. MOTOR IDENTIFICATION: MANUFACTURER'S NAME, MODEL NUMBER, VOLTAGE, FREQUENCY, INSPECTION CODE WITH "F" SUFFIX, DATE OF MANUFACTURE, AGENCY RECOGNITION CODE, PLANT LOCATION CODE, PATENT INFORMATION "ONE OR MORE OF THE FOLLOWING PATENTS APPLY TO THIS MOTOR: 5482378; 5736805; 4669952; 4684835". AND COUNTRY OF ORIGIN.
4. ALLOW [0.0016 SQ M]/2.5 SQ IN. FOR COOLING AIR INTAKE.
5. COOLING AIR INTAKE MUST BE SEPERATED FROM COOLING AIR EXHAUST.
6. COOLING AIR EXHAUST MUST BE SEPERATED FROM VACUUM AIR EXHAUST.
7. MOUNTING MUST NOT RESTRICT THIS DIAMETER.

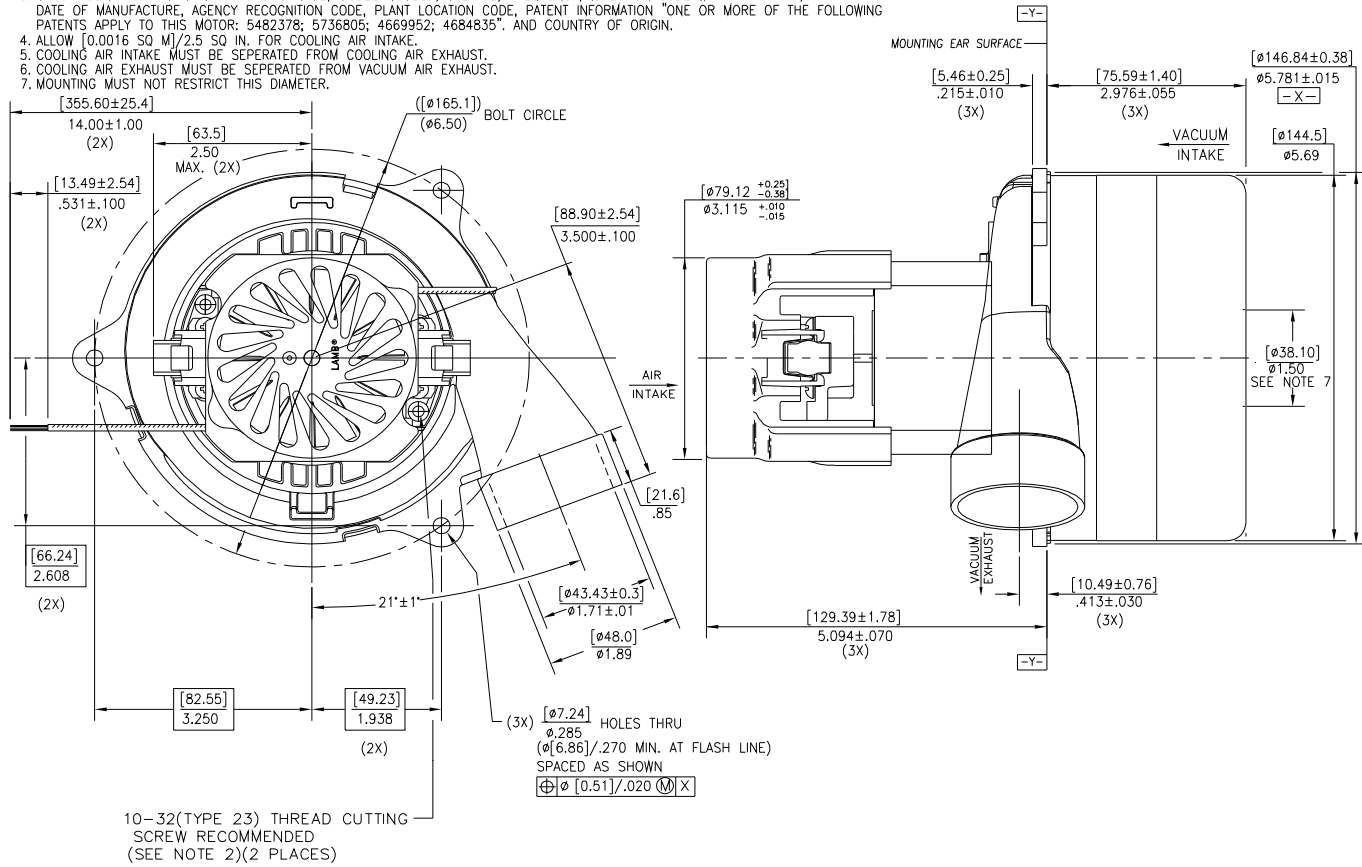

IMPORTANT NOTE: Pictorial and dimensional data are subject to change without notice. Contact factory for current revision levels.

WARNING - When using AMETEK Lamb Electric bypass motors in machines that come in contact with foam, liquid (including water), or other foreign substances, the machine must be designed and constructed to prevent those substances from reaching the fan system, motor housing, and electrical components. Lamb Electric vacuum motors other than hazardous duty models should not be applied in machines that come in contact with dry chemicals or other volatile materials. Failure to observe these precautions could cause flashing (depending on volatility) or electrical shock which could result in property damage and severe bodily injury, including death in extreme cases. All applications incorporating Lamb Electric motors should be submitted to appropriate organizations or agencies for testing specifically related to the safety of your equipment.

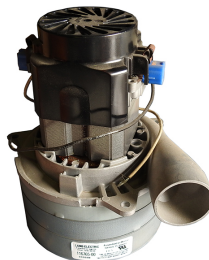

Revised: May 11, 2015