



Model: 116296-00

116296-11^ - 7610053

116296-13* - 7610052

DESCRIPTION

- Two stage
- 240 volts
- 5.7"/145 mm diameter
- Double ball bearings
- Single speed
- ACUSTEK® low-noise peripheral bypass discharge
- Thermoset fan end bracket
- Aluminum commutator bracket

DESIGN APPLICATION

- Equipment operating in environments requiring separation of working air from motor ventilating air
- Designed to handle clean, dry, filtered air only

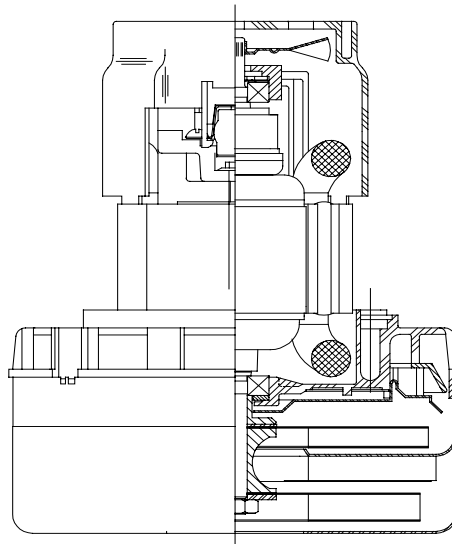

SPECIAL FEATURES

- Suitable for 240 volt AC operation, 50/60 Hz
- UL recognized, category PRGY2 (E47185)
- Provision for grounding
- Skeleton-frame design
- ACUSTEK® low-noise design, U.S. Patent #1,417,2000
- The Lamb Electric vacuum motor line offers a wide range of performance levels to meet design needs

*Model 116296-13 features patented air seal bearing construction. U.S. Patent #4,088,424 and epoxy painted fan case
 ^Model 116296-11 - Interrupter brush

TYPICAL MOTOR PERFORMANCE.*

(At 240 volts, 60Hz, test data is corrected to standard conditions of 29.92 Hg, 68° F.)

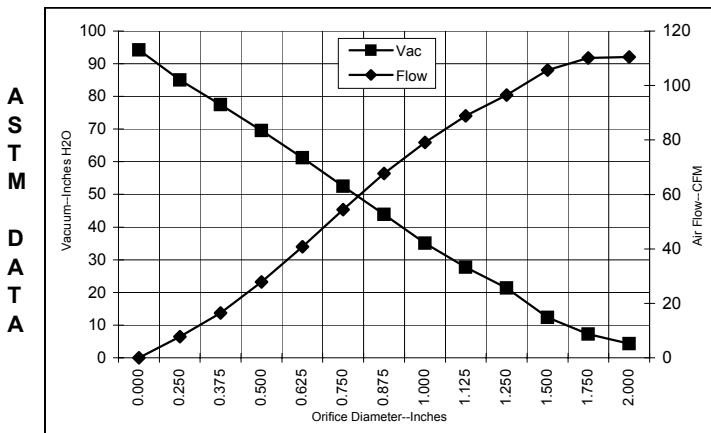

Orifice (Inches)	Amps	Watts (In)	RPM	Vac (In.H ₂ O)	Flow (CFM)	Air Watts
2.000	4.6	1064	19390	4.3	110.5	56
1.750	4.6	1071	19390	7.3	110.1	94
1.500	4.6	1077	19390	12.4	105.7	154
1.250	4.6	1077	19390	21.4	96.5	243
1.125	4.6	1073	19420	27.7	88.9	289
1.000	4.6	1067	19480	35.1	79.1	326
0.875	4.6	1049	19620	43.9	67.7	349
0.750	4.4	997	19990	52.5	54.4	335
0.625	4.1	959	20710	61.2	40.8	293
0.500	3.8	890	21600	69.5	27.8	227
0.375	3.5	818	22660	77.5	16.5	150
0.250	3.2	757	23730	85.0	7.7	77
0.000	3.0	702	24850	94.2	0.0	0

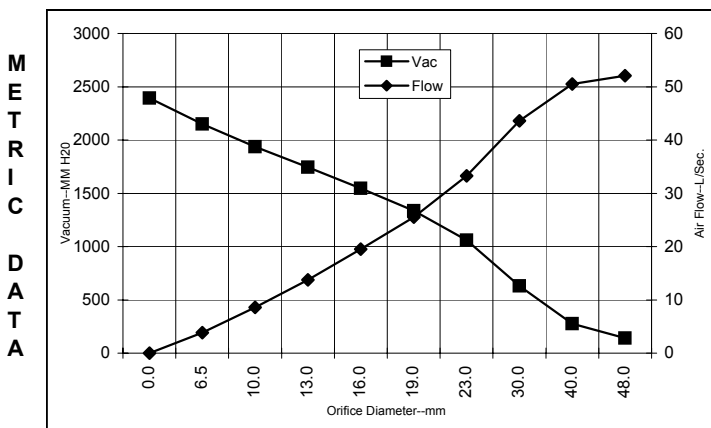

Orifice (mm)	Amps	Watts (In)	RPM	Vac (mm H ₂ O)	Flow (L/Sec)	Air Watts
48.0	4.6	1067	19390	142	52.1	73
40.0	4.6	1075	19390	275	50.5	136
30.0	4.6	1075	19407	631	43.6	268
23.0	4.6	1054	19585	1059	33.3	343
19.0	4.4	996	20004	1337	25.5	334
16.0	4.1	961	20681	1546	19.5	295
13.0	3.8	897	21511	1745	13.7	234
10.0	3.5	829	22501	1938	8.6	162
6.5	3.2	760	23677	2149	3.8	81
0.0	3.0	702	24850	2392	0.0	0

Note: Metric performance data is calculated from the ASTM data above.

* Data represents performance of a typical motor sampled from a large production quantity. Individual motor data may vary due to normal manufacturing variations.

Test Specs:	240 volts	Minimum Sealed Vacuum:	88.0"	ORIFICE:	13mm	Minimum Vacuum:	65.0"	Maximum Watts:	1000
-------------	-----------	------------------------	-------	----------	------	-----------------	-------	----------------	------

DIMENSIONS

NOTES:

1. LEADS: 18GA STRANDED, LEADS CAN BE ANY COLOR EXCEPT GREEN OR GREEN WITH YELLOW STRIPE.
2. GROUNDING OR EARTHING PROVISIONS: USE HOLES AS INDICATED FOR GROUNDING OR EARTHING. REFER TO APPROPRIATE LISTING OR REGULATORY AGENCY FOR PROPER METHOD OF GROUNDING OR EARTHING.
3. RECOMMENDED SCREW SIZE 10-16 TYPE BT OR 25 THREAD CUTTING SCREW. MAXIMUM PENETRATION 17.40/.685.

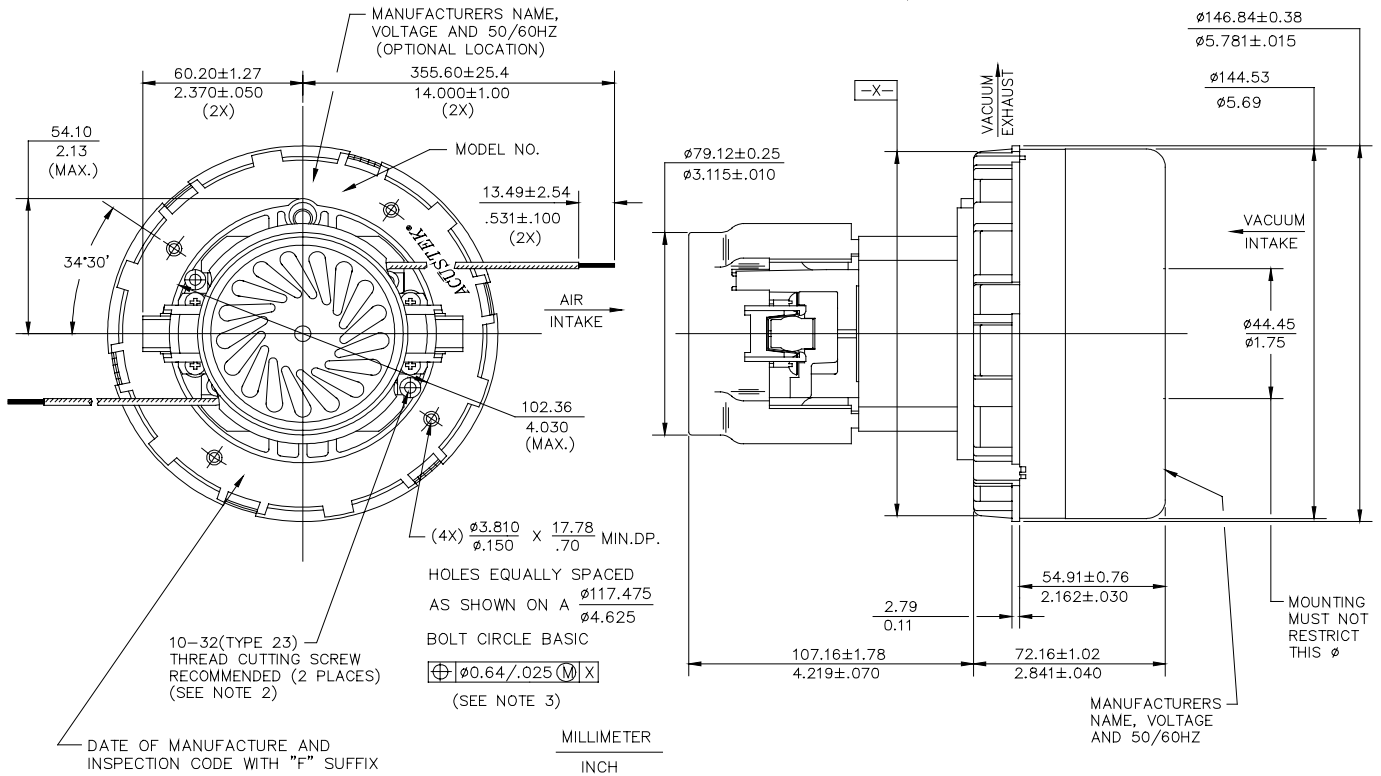

IMPORTANT NOTE: Pictorial and dimensional data are subject to change without notice. Contact factory for current revision levels.

WARNING - When using AMETEK Lamb Electric bypass motors in machines that come in contact with foam, liquid (including water), or other foreign substances, the machine must be designed and constructed to prevent those substances from reaching the fan system, motor housing, and electrical components. Lamb Electric vacuum motors other than hazardous duty models should not be applied in machines that come in contact with dry chemicals or other volatile materials. Failure to observe these precautions could cause flashing (depending on volatility) or electrical shock which could result in property damage and severe bodily injury, including death in extreme cases. All applications incorporating Lamb Electric motors should be submitted to appropriate organizations or agencies for testing specifically related to the safety of your equipment.



Issued: March, 1998