

SJE VERTICALMASTER® II AND SJE VERTICALMASTER® II PLUS PUMP FLOATS

Mechanically-activated, pump switches designed to operate in sump applications with limited space.

These mechanically-activated pump switches are designed to operate in non-potable water with limited space. They work well in small sump chambers and laundry trays, as well as in large tanks. These switches are not recommended for a sewage environment.

These switches not sensitive to turbulence.

Available for pump down applications only.



SPECIFICATIONS

- Flexible SJTOW, SJTW cable
- Stainless steel mounting bracket and hose clamp
- Acetal plastic lift rod
- Neoprene float stop
- High impact, corrosion resistant, PVC float and switch housing
- Temperature rating up to 52° C (125° F)
- IPX7 enclosure protection
- Suitable for Category II installations
- Protected by double-insulation
- Adjustable pumping range 2 cm to 17 cm (0.75 inches to 6.5 inches)
- Dimensions:
Overall dimensions: 30.5 cm high x 12.7 cm x 7.6 cm wide (12 inch high x 5 inch x 3 inch wide)
Switch housing dimensions (excluding cable entrance): 5 cm high x 7.1 cm diameter (2 inch high x 2.8 inch diameter)
Float housing dimensions: 6.4 cm high x 6.9 cm diameter (2.5 inch high x 2.7 inch diameter)
- CE Certified units available by request
- Must be used with pumps that provide integral thermal overload protection

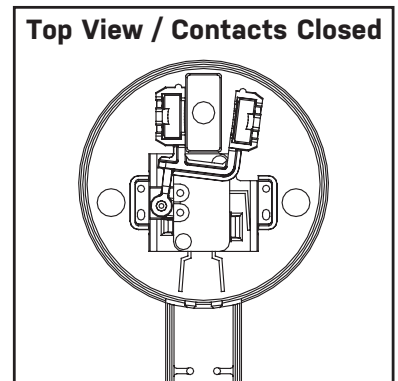
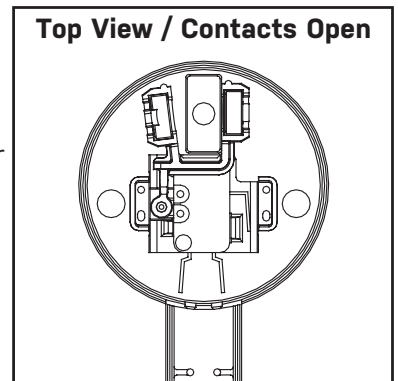

MODEL SPECIFIC SPECIFICATIONS

SJEVERTICALMASTER® II pump float		
Voltage 50 Hz/60 Hz Single Phase	Maximum Pump Running Current	Maximum Pump Starting Current
125/250 VAC	10 amps	60 amps
Cable:	18 gauge, 2 conductor	

SJEVERTICALMASTER® II PLUS pump float		
Voltage 50 Hz/60 Hz Single Phase	Maximum Pump Running Current	Maximum Pump Starting Current
125/250 VAC	12 amps	78/72 amps
Cable:	16 gauge, 2 conductor	

Pump Down is normally open contacts for emptying.



*The data provided above is for information purposes only and no warranty of accuracy or reliability is given.
Ross Brown Sales Pty Limited reserves the right to change or modify this data without prior notice.*

SJE VERTICALMASTER® II AND SJE VERTICALMASTER® II PLUS PUMP FLOATS

OPTIONS

Mounting Bracket and Hose Clamp are standard

Boxed Packaging is standard - Bulk packaging is not available.

Piggy-Back Plug - North American standard plug. Please contact the factory.

CE Certified units available upon request.

Ordering Information

RBS Stock Code	Description
3710190	Vertical Master II, 3mtr, No Plug
3710195	Vertical Master II, 5mtr, No Plug
3710200	Vertical Master II, 10mtr, No Plug
3710191	Vertical Master II, 3mtr, With Plug*
3710196	Vertical Master II, 5mtr, With Plug*

* Fitted with piggyback plug. Allows you to plug in the pump directly, no further wiring required.



SJE RHOMBUS

9500201E 07/20
© 2018 SJE, Inc. All Rights Reserved.
SJE RHOMBUS is a trademark of SJE, Inc.

*The data provided above is for information purposes only and no warranty of accuracy or reliability is given.
Ross Brown Sales Pty Limited reserves the right to change or modify this data without prior notice.*