

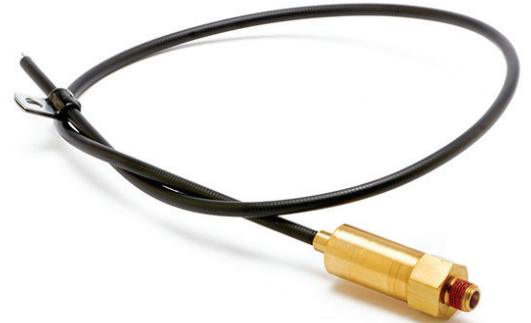

# THROTTLE CONTROLS

## TC12 Standard Throttle Control

The TC12 Throttle Controls are used on gas engine-driven compressors to reduce engine speed to idle when the continuous run control (such as CDI Models LGM20, LGM30, and LGM40 vent unloaders or Model P25 pilot valve) has reached its "cut-out" setting. This reduces noise, saves fuel and reduces engine and compressor wear.



The 1/8" NPT inlet of the TC12 is connected to the throttle control port of the vent unloader or connected into a "tee" of the head unloader line of pilot valve installations. The cable end is attached to the appropriate throttle linkage on the engine and the cable housing is appropriately anchored using the supplied cable clamps.

In operation, the vent unloader or pilot valve sends a pressure signal to the TC12 at the cut-out setting. This causes the TC12 piston to extend the control cable, which pushes the throttle lever, causing the engine to idle down. At the cut-in setting, the pressure signal going to the TC12 is vented, allowing the spring to return the piston, cable and throttle lever to the original full speed position.

Materials of construction are brass body and piston with nitrile o-ring and zinc plated steel spring and retaining ring. Vinyl covered, steel armoured housing with stainless steel cable.

- Max temperature 120° C.
- Minimum pressure 60 PSI (415 kPa).
- Maximum pressure 250 PSI (1725 kPa).
- Used with engines up to 8 HP.

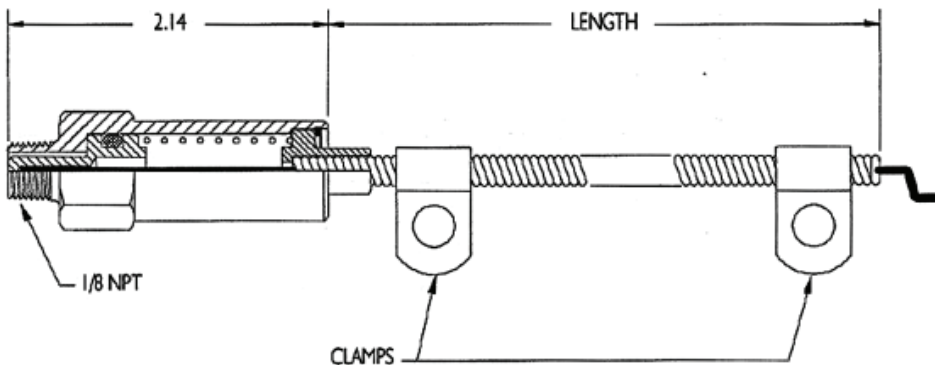

Cable Length	Part Number
36"	4003036
44"	4003044
48"	4003048
54"	4003054
62"	4003062

## TC12 Large Throttle Control

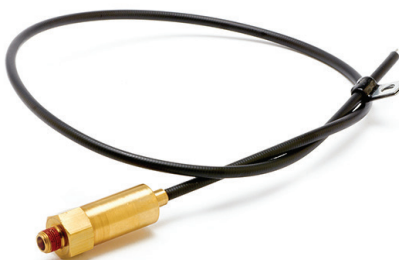

A larger version of the TC12 Standard Throttle Control to be used with engines above 8 HP.

Cable Length	Part Number
48"	4003248

*The data provided above is for information purposes only and no warranty of accuracy or reliability is given. Ross Brown Sales Pty Limited reserves the right to change or modify this data without prior notice.*