

CORROSION HANDLER® 300 A1 SE2 F2

SALES GUIDE



INTRODUCTION

Drain-All No-loss condensate traps provide unique, high quality, energy efficient, reliable product solutions for draining and moving liquids such as: (1) condensate removal from compressed air systems, (2) oils and lubricants from manufacturing or test equipment, and (3) liquids from atmospheric and vacuum systems. Drain-All condensate traps are produced under a certified ISO 9001 Quality Management System to ensure the product exceeds customer expectations.

Drain-All products are industrially robust, require little maintenance and since they do not require any electrical connections, can be easily installed on equipment at any point in a system. The unique design maintains a liquid barrier inside the trap which prevents the escape of costly process gas. As a result, no-loss condensate traps provide energy savings when compared to timer drains and manual valves. These patented devices are backed by an excellent warranty and a strong technical support staff who are available to assist customers in developing engineered solutions for all of their liquid drainage problems.

The Drain-All product line includes a wide array of products, options and accessories which enable customers to customize their particular liquid drainage systems. The Drain-All condensate drains are compatible with all manufactures of compressors, aftercoolers, filters/separators, receivers and dryers.

SPECIFICATIONS	
Part Number	CH50-0MASF2
Max Liquid Temp - °F (°C)	170 (76.7)
Max Liquid Pressure – PSIG (BARG)	300 (20.7)
Control Air Min – PSIG (BARG)	40 (2.8)
Control Air Max – PSIG (BARG)	130 (9.0)
Ht – inches (cm)	11 (27.9)
Width – inches (cm)	9-1/4 (23.5)
Depth (Inlet/BV) – inches (cm)	10-1/2 (26.7)
Inlet / Outlet – NPT	1/2
Control Air – NPT	1/4
Balance Line – NPT	1/8
Max Capacity @ 110 PSI - GPM (kg/hr)	1.5 (340) *
Weight – LBS (KG)	21 (9.5)

* Varies with pressure/piping

Quality System ISO 9001 Certified United States Patent: 5,983,919



ABN 28 000 690 362
TEL: (02) 8855 1700
EMAIL: sales@rossbrownsales.com.au
WEBSITE: www.rossbrownsales.com.au



a product of
Control Devices, LLC

COMPONENT PARTS DRAWING

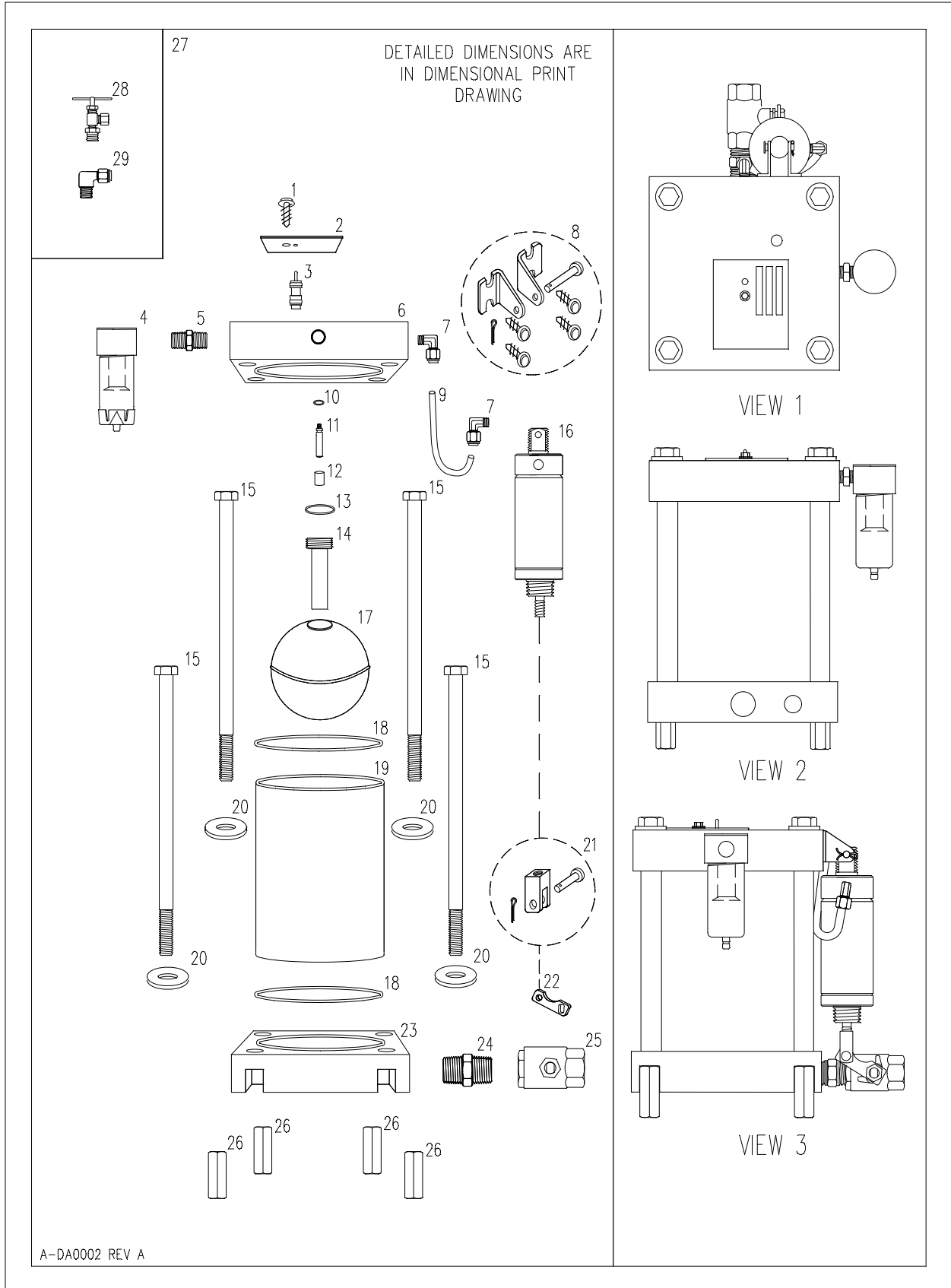

PARTS & MATERIALS OF CONSTRUCTION

CODE	PART #	ITEM	DESCRIPTION/REMARKS	QTY
1	302511	Screw, Self-Tapping	Stainless Steel	1
2	302806	Name Plate	Aluminum	1
3	300600	Push to Test Button	Brass	1
4	300706	Filter Assembly, Control Air	Aluminum	1
5	300800	Hex Nipple, 1/4" NPT	Brass	1
6	170179	Head, Tapped Holes	Black Anodized, Aluminum	1
7	301000	Elbow Fitting, 1/8" NPT - 1/4" Tube	Brass	2
8	300295	Cylinder Mount Kit	Includes:	1
			(2) Bracket-Stainless Steel	
			(1) Mount Pin-Stainless Steel	
			(1) Cotter Pin-Stainless Steel	
			(4) Screw, Stainless Steel	
9	350352	Control Air Tube, 1/4" Dia x 7" L	Nylon	1
10	302210	O-ring, Valve Stem	Viton, Brown	1
11	100731	Valve Stem, 2.009" L	O-ring Seal, Aluminum	1
12	400100	Inner Magnet	Ceramic with Viton Ends and Covering	1
13	302215	O-Ring, Center Tube	Viton, Brown	1
14	200172	Center Tube, 4.3" L	O-ring Seal, Aluminum	1
15	302312	Hex Bolt	Stainless Steel	4
16	300314	Pneumatic Cylinder, 2" Dia	40 - 130 PSI, Stainless Steel Body and Rod, Aluminum Ends	1
17	100460	Float	Stainless Steel, Spherical	1
18	302200	O-ring, Sleeve	Viton, Brown	2
19	100300	Sleeve, 1/8 Thick	Epoxy Fiberglass, Translucent	1
20	301571	Washer	Stainless Steel	4
21	300308	Clevis and Pin Kit	Includes:	1
			(1) Clevis-Stainless Steel	
			(1) Clevis Pin-Stainless Steel	
			(1) Cotter Pin-Stainless Steel	
22	100807	Control Lever	Stainless Steel for 1/2" NPT Ball Valve	1
23	170270	Base, 1/2" NPT	Through Ported, Black Anodized Aluminum	1
24	300901	Hex Nipple, 1/2" NPT	Brass	1
25	300207	Heavy Duty Ball Valve, 1/2" NPT	Double O-ring Viton Stem Seals, Nickel Plated Brass	1
26	302376	Coupling Nut	Stainless Steel	4
27	351135	Installation Kit	Includes:	1
28			(1) Needle Valve-Brass	
29			(1) Elbow Fitting-Brass	

DIMENSIONAL PRINT

