

Model: 116670-50 - 7610086

DESCRIPTION

- Two stage
- 240 volt
- 5.7"/145 mm diameter
- Ball/sleeve bearings
- Single speed
- Thru-flow discharge
- Aluminum fan end bracket
- Aluminum commutator bracket

DESIGN APPLICATION

- Equipment operating in environments not requiring separation of working air from motor ventilating air
- Designed to handle clean, dry, filtered air only

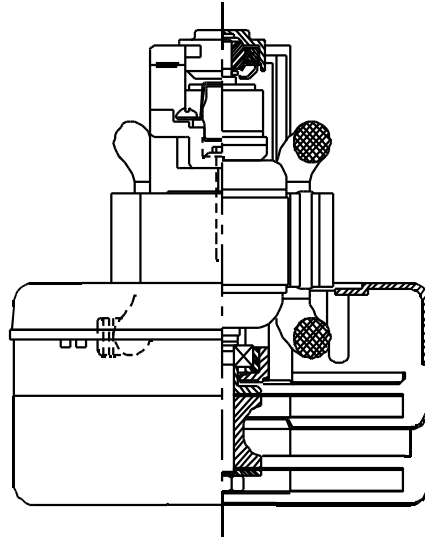

SPECIAL FEATURES

- Suitable for 240 volt AC operation, 50/60 Hz
- UL recognized, category PRGY2 (E47185)
- CSA certified, class 1611 01 (LR31393)
- Provision for grounding
- Skeleton-frame design
- Thermal protection, automatic reset, UL category XEWR2 (E27701)
- The Lamb Electric vacuum motor line offers a wide range of performance levels to meet design needs

TYPICAL MOTOR PERFORMANCE.*

(At 240 volts, 60Hz, test data is corrected to standard conditions of 29.92 Hg, 68° F.)

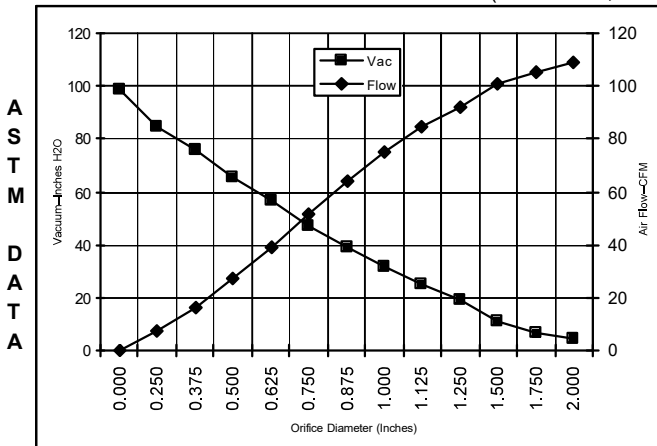

Orifice (Inches)	Amps	Watts (In)	RPM	Vac (In.H ₂ O)	Flow (CFM)	Air Watts
2.000	4.2	977	19117	4.2	108.9	53
1.750	4.3	1000	18979	6.6	105.3	82
1.500	4.3	1016	18841	11.3	101.2	135
1.250	4.4	1029	18566	19.4	91.9	210
1.125	4.4	1037	18566	25.0	84.5	248
1.000	4.4	1031	18566	31.5	75.0	278
0.875	4.3	1009	18831	39.1	64.0	294
0.750	4.0	970	19255	47.3	51.7	288
0.625	3.8	913	20007	56.7	39.3	262
0.500	3.5	841	21014	65.7	27.1	209
0.375	3.2	769	22254	75.5	16.3	145
0.250	2.8	705	23557	84.9	7.7	77
0.000	2.6	643	24659	98.6	0.0	0

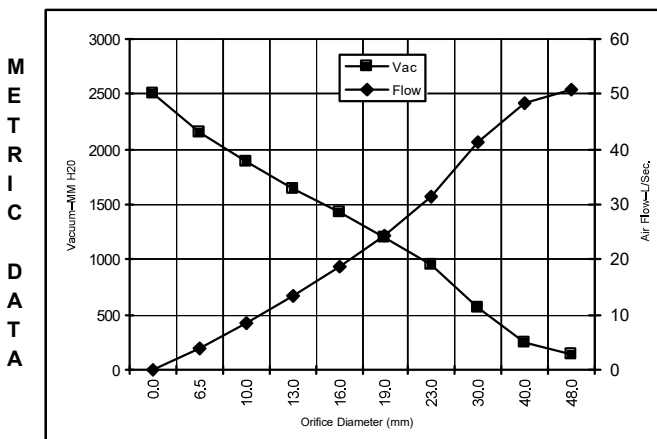

Orifice (mm)	Amps	Watts (In)	RPM	Vac (mm H ₂ O)	Flow (L/Sec)	Air Watts
48.0	4.2	987	19056	133	50.7	66
40.0	4.3	1011	18882	251	48.3	119
30.0	4.4	1033	18566	571	41.5	231
23.0	4.3	1015	18765	945	31.5	290
19.0	4.0	969	19270	1206	24.3	287
16.0	3.8	915	19977	1431	18.8	263
13.0	3.5	848	20913	1646	13.4	214
10.0	3.2	780	22068	1880	8.5	155
6.5	2.9	708	23492	2145	3.8	80
0.0	2.6	643	24659	2504	0.0	0

Note: Metric performance data is calculated from the ASTM data above.

* Data represents performance of a typical motor sampled from a large production quantity. Individual motor data may vary due to normal manu

Test Specs:	240 volts	Minimum Sealed Vacuum:	89.0"	ORIFICE:	7/8 "	Minimum Vacuum:	35.0"	Maximum Watts:	1070
-------------	-----------	------------------------	-------	----------	-------	-----------------	-------	----------------	------